

DESIGN NOTES

Dual-Phase High Efficiency Mobile CPU Power Supply Minimizes Size and Thermal Stress – Design Note 247

Wei Chen

Introduction

The increasing demand for computing power in notebook computers has significantly increased CPU clock frequencies and supply currents. Forthcoming mobile CPUs call for core currents as high as 25A to handle sophisticated computing tasks. Traditional single-phase solutions have difficulty delivering such a high current. When the CPU supply voltage (0.7V to 1.8V) is converted directly from a high voltage (21V max) adapter input, single-phase MOSFET drivers are not strong enough to efficiently drive high current MOSFETs without dV/dt

shoot-through problems. The resulting excessive power loss in the MOSFETs increases thermal stress close to the CPU and reduces the battery run time. The physical size of a high current (25A) inductor becomes unacceptably large and more low ESR output capacitors are required to handle larger load steps. Also, current crowding in PCB traces near the inductor pads raises reliability concerns. As a result, the single-phase solution is inefficient, bulky and can cause long-term reliability issues.

LT, LTC and LT are registered trademarks of Linear Technology Corporation. Burst Mode is a trademark of Linear Technology Corporation.

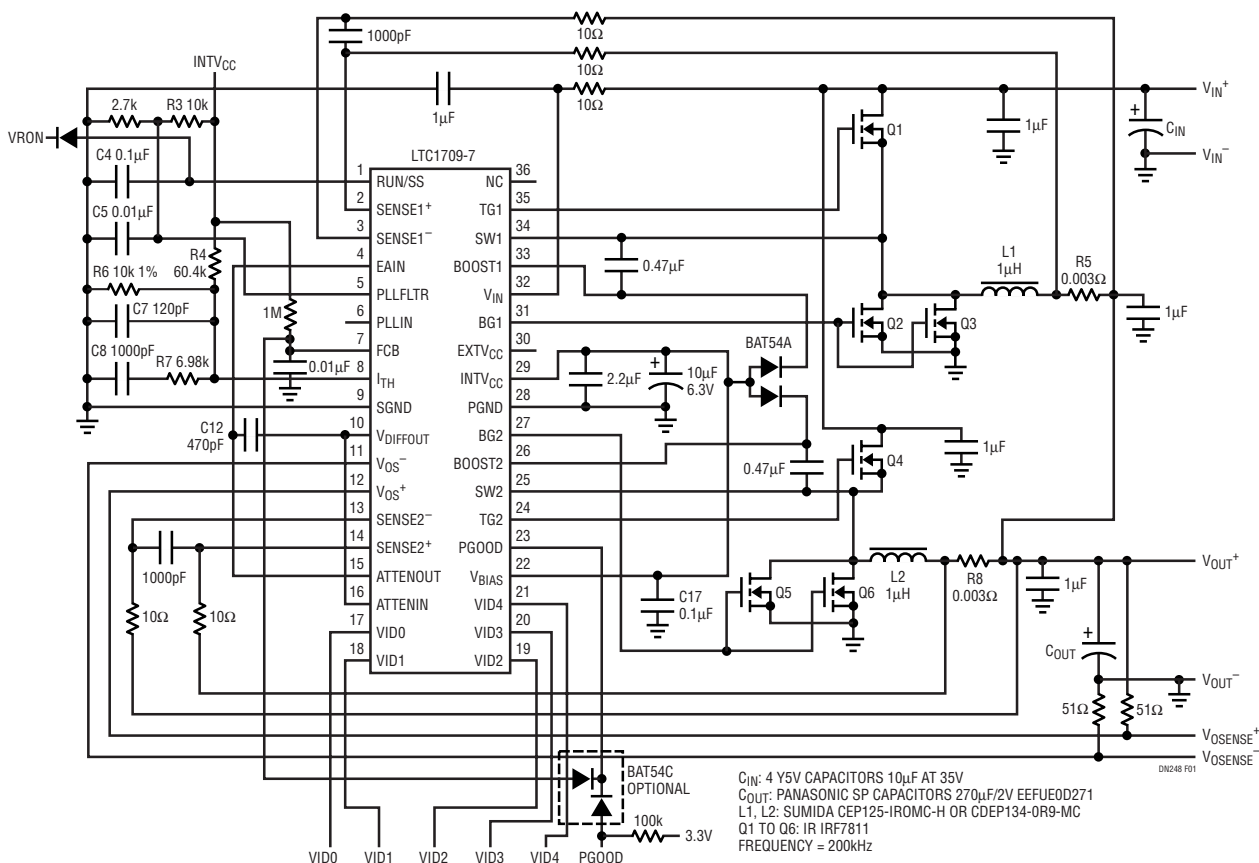

Figure 1. Schematic Diagram of a 25A Mobile VRM

Dual-phase switching is the best solution for this application. The LTC[®]1709-7 is a dual-phase controller that drives two synchronous buck stages 180 degrees out of phase, reducing input and output capacitors without increasing the switching frequency. The relatively low switching frequency and integrated high current MOSFET drivers help achieve high power conversion efficiency to maximize battery run time. Because of output ripple current cancellation, lower value, low profile inductors can be used, resulting in faster load-transient response and reduced component height. The LTC1709-7 also features discontinuous conduction mode and Burst Mode[™] operation to minimize power losses when the CPU is in “sleep” mode. Because current is divided equally between two identical channels, heat is distributed uniformly and long-term PCB reliability is improved.

Design Example

Figure 1 shows the schematic diagram of a 25A mobile CPU core power supply. With only one IC, six tiny SO-8 MOSFETs and two 1 μ H, low profile, surface mount inductors, an efficiency of about 85% is achieved for a 15V input and a 1.6V/25A output. Greater than 80% efficiency can be maintained throughout the load range from 5A to 25A.

Figure 2 shows the measured load transient waveform. The load current changes between 0A and 25A. The slew rate is 30A/ μ s. With only four SP capacitors (270 μ F/2V) at the output, the maximum output voltage variation during the load transient is less than 190mV_{p-p}. Resistors R4 and R6 provide the active voltage positioning with no loss in efficiency. Without the active voltage positioning, three more SP capacitors would be needed.

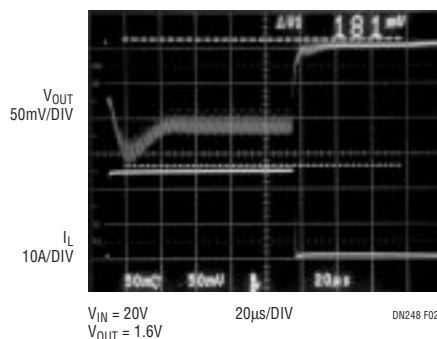

Figure 2. Load Transient Waveforms at 25A Step and 30A/ μ s Slew Rate

Table 1 compares the performance and key component selections of the single-phase and dual-phase designs. The dual-phase technique saves two 270 μ F SP output capacitors and two 10 μ F ceramic input capacitors. With the same number of MOSFETs and the same switching frequencies, the dual-phase solution achieves much better efficiencies. The higher efficiency in the dual-phase circuit, with more uniform current distribution, dramatically reduces the temperature rises in the MOSFETs and inductors.

Conclusion

Compared to the conventional single-phase solution, the LTC1709-7 based, dual-phase mobile VRM achieves higher efficiency, smaller size and lower solution cost. The dual-phase solution extends battery life, minimizes thermal stress and improves long-term reliability.

Table 1. Comparisons of Single-Phase and Dual-Phase Solutions (Switching Frequency is 200kHz)

	Single Phase	Dual Phase
MOSFETs: IRF7811	Six (2 for Top, 4 for Bottom)	Six (per Phase, 1 for Top, 2 for Bottom)
Inductors and Sizes (L \times W \times H, Unit: mm)	One 1 μ H/25A (14.6 \times 14.6 \times 9)	Two 1 μ H/13A (12.5 \times 12.5 \times 4.9 Each)
Input Capacitors	Six 10 μ F/35V, Y5V Capacitors	Four 10 μ F/35V, Y5V Capacitors
Output Capacitors	Six SP Capacitors, 270 μ F/2V	Four SP Capacitors, 270 μ F/2V
Efficiency: $V_{IN} = 20V$, $V_{OUT} = 1.6V$, $I_{OUT} = 25A$	80%	83%
Max Temperature*: $V_{IN} = 21V$, $I_{OUT} = 25A$, $V_{OUT} = 1.6V$	Inductor	110 $^{\circ}C$
	MOSFETs	104 $^{\circ}C$

*Open air, after 20 minutes full-load operation. The temperatures are measured on the top surface of the components.

Data Sheet Download

<http://www.linear-tech.com/go/dnLTC1709-7>

For literature on our Switching Regulators, call **1-800-4-LINEAR**. For applications help, call (408) 432-1900, Ext. 2593